



DENALI Plow Mount MA11757 Coleman 800

Note: 2012-2013 Coleman machines require 2 holes to be drilled. This does not void manufacturer warranty.

Thank you for purchasing our DENALI plow mount. You now own a premium custom plow mount to allow you to use your plow with your SxS. Please note the following instructions and heed all warnings.

- Your UTV/SxS and/or plow system can cause death or injury, please use caution and common sense when operating your unit.
- Read your Plow Operator Manual, your Winch Operator Manual, and all warning labels before operating your UTV/SxS.
- Operate your UTV/SxS at a walking speed with the blade installed. Do not exceed 5 mph (8 km/h), even with the blade up.
- Do not operate the UTV/SxS on slopes greater than 10 degrees with the plow installed.
- Always lower the plow to the down position before leaving your UTV/SxS unattended.

SEVERE INJURY OR DEATH MAY RESULT IF YOU ARE NEGLIGENT.

Please verify that all hardware and parts are included in your package.

Kit Content: Please refer to Figure 1

Item Number	Quantity	Part Number
1	1	MA11757 Plow Mount
2	2	Rear Buckles
3	2	M10-1.25 x 25mm HH Bolt
4	2	M10 Lock Washer
5	2	M10 Flat Washer
6	4	3/8" x 1 1/4" Carriage Bolt
7	4	3/8" Flat Washer
8	4	3/8" Nylock Nut

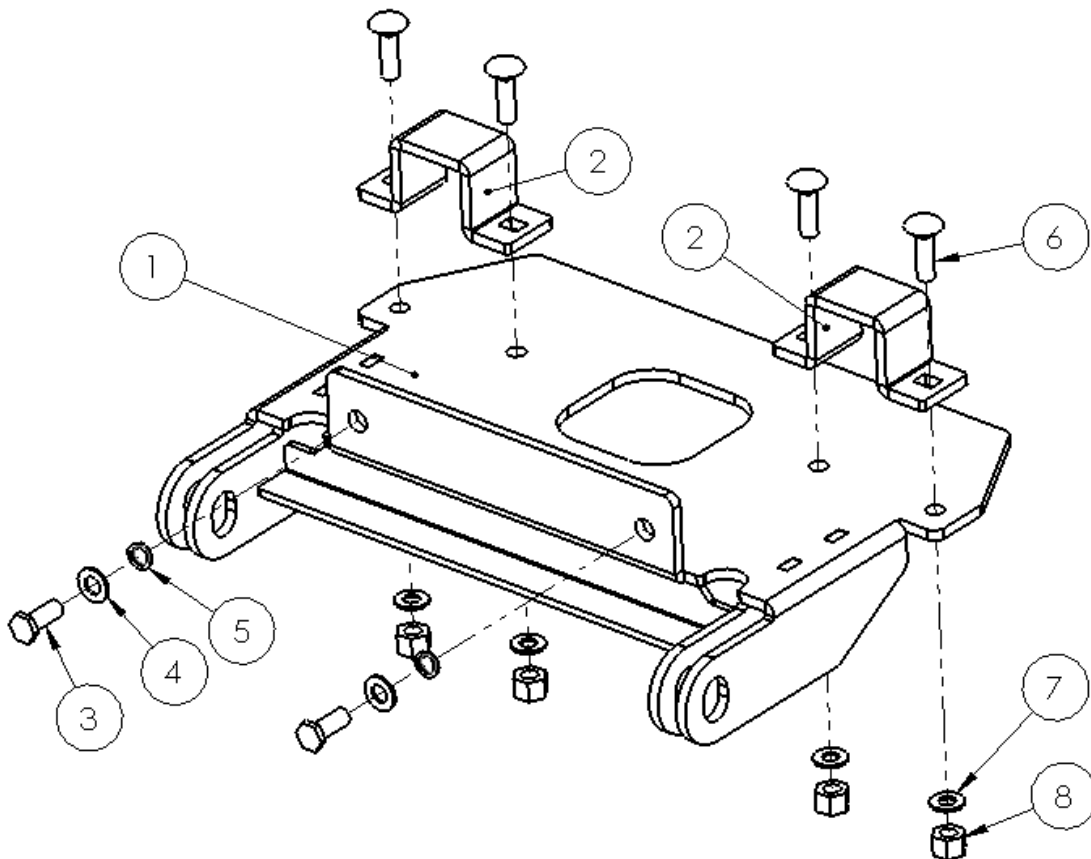

Figure 1

Coleman Installation Instructions

1. Begin by trimming the front portion of the plastic underbody on the Coleman 800. Remove the (6) front screws to gain additional access to the plastic underbody. Use a razor blade and straight edge to score the plastic several times until it can be removed. See Figure 2, Figure 3, and Figure 4.

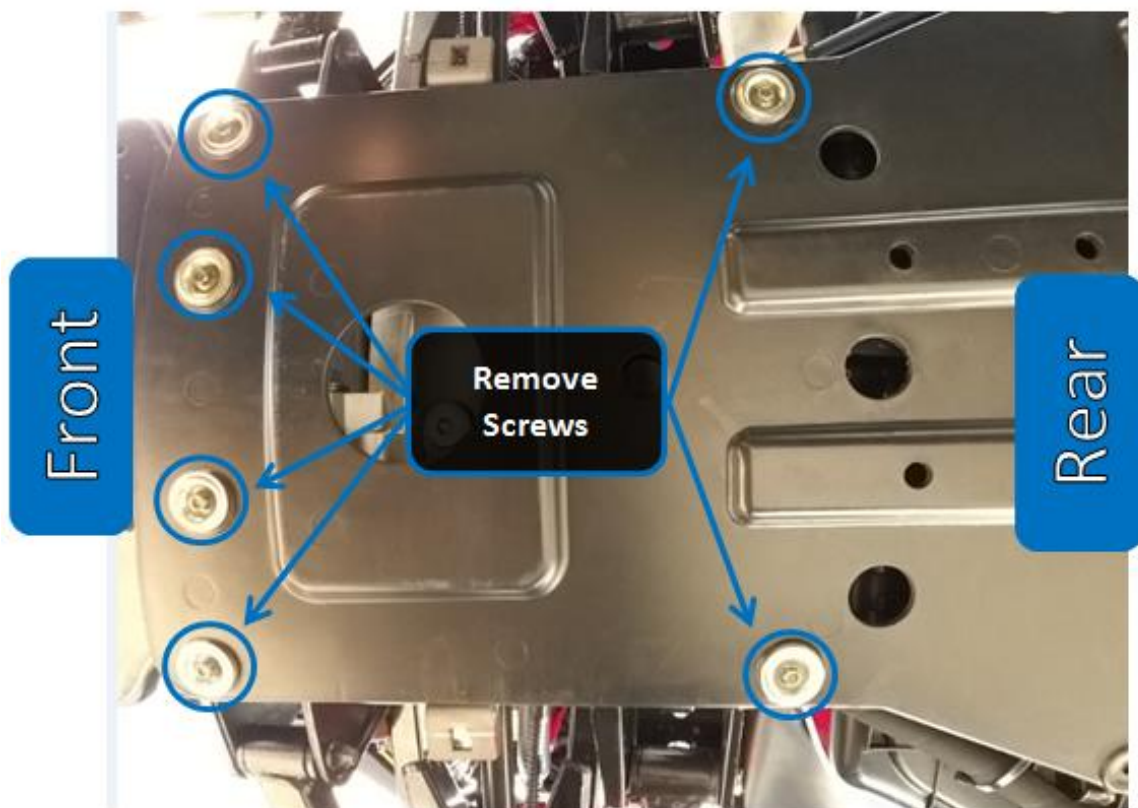

Figure 2

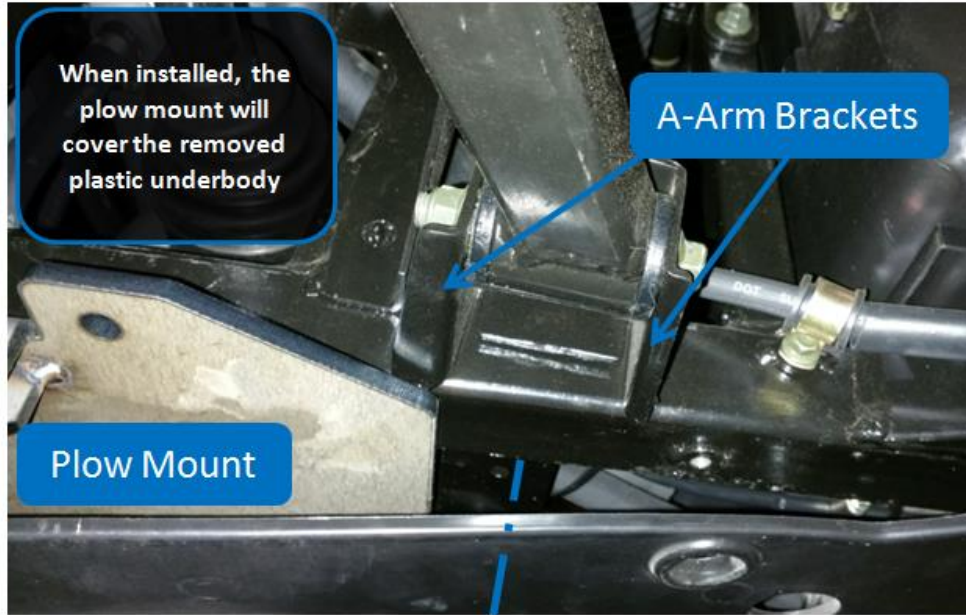

Figure 3

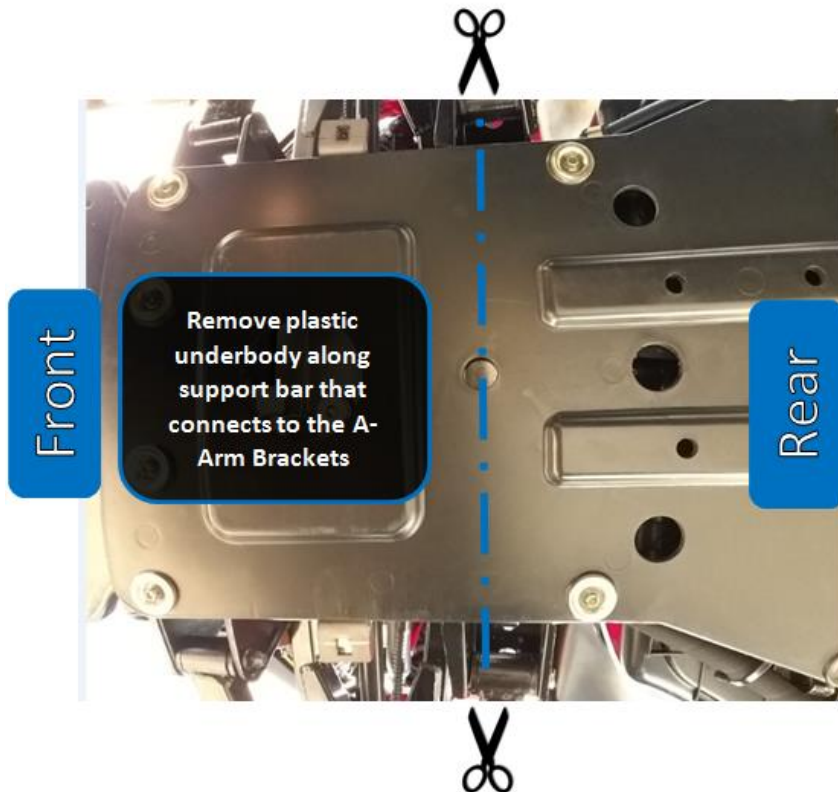

Figure 4

2) Hold the mount plate to the front end of the machine and attach it using the (2) M10-1.25mm x 25mm Hex Bolts, (2) M10 Lock Washers and (2) M10 Flat Washers. Do not tighten these bolts at this time. See Figure 5. **NOTE: If you have a 2012-2013 machine, the two front bolts must be drilled and tapped. Mount the rear straps and hold the front end to the frame of the Coleman. Mark the two hole locations and drill/tap for M10-1.25 or equivalent size bolts.**



Figure 5

3) With the front of the mount attached, snip the two zip ties that secure the rubber hoses along the inside of the chassis. The hoses are located along the chassis next to the Lower A-Arms. See Figure 6.

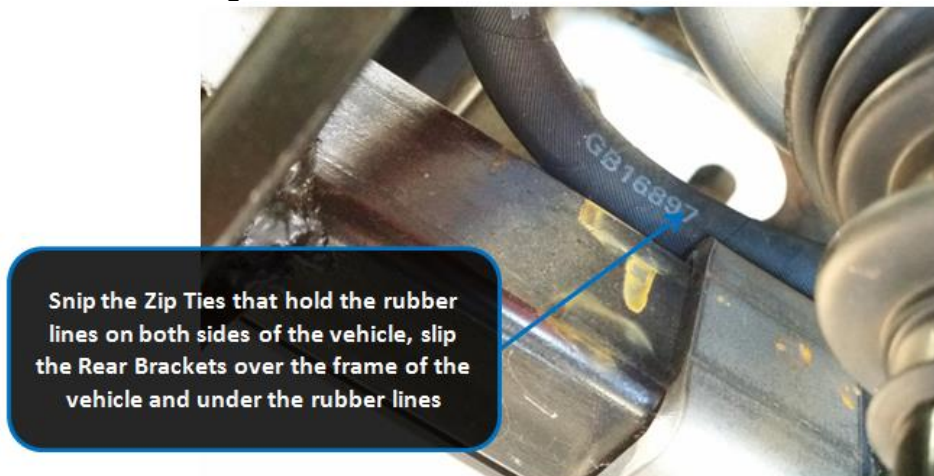

Figure 6

4) Lift up the rubber hose and insert the (2) Rear Buckles over the Chassis rails, such that the holes line up between the Rear Buckles and the Main Mounting Plate. Insert the 3/8" Carriage Bolts from above the Rear Buckles and pass them through the Main Mounting Plate holes. Secure the bolts with the 3/8" Flat Washers and 3/8" Nylock Nuts.



Figure 7

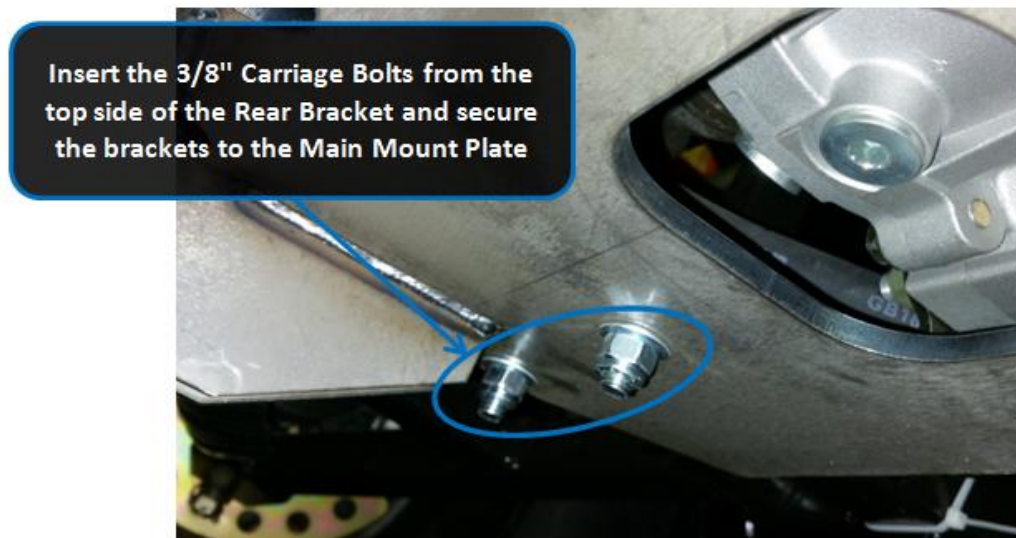

Figure 8

5) Tighten all bolts and reinstall (2) of the six bolts removed in Step #1 into the Plastic Underbody. Attach your plow per the manufacturer's instructions.